

# **karma**

A Better Wheelchair, A Better Fit

## *Manual Wheelchair Owner's Manual*

### Ergo Live Series

(KM-9000)



CE



---

## GENERAL WARNING

- DO maintain your wheelchair well, in particular check the tire pressure since this affects the efficiency of the brakes. To know the correct tire pressure, please see the walls of the tires.
- DO make sure both brakes are applied before getting in or out of the wheelchair.
- DO make sure both brakes are applied when the wheelchair is not being pushed or used.
- DO take care when climbing kerbs or turning on slopes.
- DO avoid steep or uneven surfaces that may cause the wheelchair to tip over.
- DO avoid soft surfaces as the casters may become bogged down.
- DO travel smoothly in all conditions.
- DO look well ahead to anticipate hazards such as furniture, doors, potholes, etc.
- DO make sure that both user's feet are safely on the footrests and the clothing is safely tucked out of the way so that it cannot get caught in the wheels.
- DO take care when traveling up or down or across inclines.
- DO keep both hands on the push handles to control the wheelchair, if you are the attendant.
- DO pay attention to keep the wheelchair balanced.
- DO check the frame and components regularly and refer to this owner's manual during and after the warranty period.
- DO tie-up the upholstery or replace it with a new one when it becomes loose.
- DO lubricate bearings regularly.
- DO equip with anti-tippers to avoid falling backwards.
- DO equip with a seat belt designed for disabled users.
- DO equip with "heel loops" for disabled users.
- DO clean both hands after oiling the wheelchair.
- DO keep far away from flame.
- DO make sure the surface temperatures can increase when the wheelchair is exposed to external sources of heat (e.g. sunlight);
- DO pay attention to the environment, and to keep away from the hazard of external flame in spite of the seat having passed EN 1021-1/-2 test .  
When the user is smoking, pay attention to safety and make sure to extinguish the fire when finished. Be alert to the environment when

---

someone nearby is smoking or using a cigarette lighter, keep away from the hazard and use fire-proof cloth.

- DO NOT overload the wheelchair in any circumstance.
- DO NOT hang anything heavy on the back of the wheelchair that could cause the wheelchair to become unstable, particularly when negotiating inclines.
- DO NOT allow more than one user at a time.
- DO NOT have any unconscious patient use the wheelchair.
- DO NOT use other transport to pull the wheelchair.
- DO NOT do "wheelies", since you might fall or tip over backwards and suffer a severe injury.
- DO NOT sit in the wheelchair within a moving vehicle unless it has been affixed the labels of hook mark. The labels of hook mark mean that the wheelchair fulfils the performance requirements for a "Crash Test" of ISO 7176-19 and is suitable to use as a seat in vehicles that have been adapted for this purpose.



**WARNING:**

- **As of this date, the KM-9000 series have NOT been tested for safety in collisions according to ISO 7176-19. Therefore, the KM-9000 series cannot be used as seats in any vehicles. That is, KARMA recommends that users are NOT transported in any vehicle while seated in the wheelchair. In the case of accident or a sudden stop, the user could be thrown from the wheelchair and get injured. The suggested solution is to transfer the user from the wheelchair into a normal seat of the vehicle and to securely stow the wheelchair in a separate compartment.**
- DO NOT go too fast or turn too quickly.
- DO NOT stand on the footplates when getting in or out of the wheelchair.
- DO NOT go down steps forward, whether solo or with an attendant.
- DO NOT attempt to lift the wheelchair by any removable (detachable) parts. Lifting by means of any removable (detachable) parts of the wheelchair may result in injury to the user and/or assistant or damage to the wheelchair.
- Do NOT use the wheelchair when the back is folded. This alters the center of gravity and may cause the wheelchair to tip backwards. The back should only be folded for storage or transport of the wheelchair.
- DO NOT hang anything on the back joint that could cause the backrest folding

---

suddenly and may cause injury.

- We estimate a life expectancy of five years for the product, provide it is used strict accordance with the intended use as set out in this document and all maintenance and service requirements are met. The estimated life expectancy can be exceeded if the products is carefully used and properly maintained. The life expectancy can be reduced by extreme or incorrect usage.

## **YOU AND YOUR KARMA SERVICE PROVIDER**

- No tools are required for assembly. Your wheelchair should be assembled by your authorized KARMA dealer. Your authorized KARMA dealer is also your service provider. Unauthorized repairs, upgrades and add-ons will void your warranty. Anything wheelchair related that requires tools should be done by your authorized KARMA service provider. Your KARMA service provider has the necessary service/maintenance manual for your wheelchair.
- If you have any defective parts or lose any parts, please contact your dealer for repair and/or replacement. Please only use parts authorized by KARMA. Use of parts that are not authorized by KARMA will void your warranty.
- Part numbers are listed on our bill of materials (explosion drawings), which we give to our authorized dealers and service providers. Customers should order parts through their dealer as well as all repairs and scheduled maintenance.
- Customers should go to their dealer for all service needed to guarantee their warranty is not void. Always go to an authorized service provider. Unauthorized repairs will void your warranty. Procedures other than those described in this manual must be performed by a qualified technician. They also have the service manual with a complete list of maintenance required to keep your KARMA wheelchair in top performance. Check the warranty section of this manual to find out what KARMA guarantees and what maintenance and parts that are not covered by our warranty.
- KARMA does not have an official list of service providers at this time. Please contact your dealer for service. If you cannot contact your dealer, please contact another authorized KARMA dealer for service. If all else fails, contact KARMA

---

directly via our website or give us a call and we can refer you to your new service provider.

## CE MARKING

- This wheelchair complies with the requirements of the Medical Devices Directive 93/42/EEC.



### CAUTION:

- When prescribing wheelchairs for use by full or partial amputees (above or below knee, single or double) or other conditions that affects the user's natural center of gravity and might cause the wheelchair to tip or the person on the wheelchair to fall off, we suggest contacting your therapist or dealer as well as attaching anti-tippers, pelvic belt, or other additional safety accessories.
- When using the wheelchair, ALWAYS follow the Highway Code or your local traffic regulations when outdoors and the guidelines written in this manual.

# TABLE OF CONTENTS

1. PREFACE.....	1
2. SAFETY.....	1
2.1 Doorways .....	2
2.2 Leaning.....	2
2.3 Negotiating Inclines.....	2
2.4 Kerbs .....	2
2.5 Stairs.....	3
2.6 Streets.....	3
2.7 General.....	3
2.8 Upholstery .....	4
2.9 Anti-Tippers.....	4
2.10 Maximum User Weight Limit.....	4
2.11 Avoid General Misuse .....	4
2.12 Labeling.....	6
3. INTENDED USE & PARTS .....	7
3.1 Intended Use.....	7
3.2 KM-9000 with 24" Rear Wheel Parts Description.....	8
4. OPERATION .....	9
4.1 Unfolding .....	9
4.2 Folding .....	10
4.3 Getting Into Your Wheelchair (See Figure 4.7) .....	10
4.4 Getting Out of Your Wheelchair .....	10
4.5 Rear Wheel Disassembly .....	11
4.6 Rear Wheel Assembly .....	11
4.7 Wheel Locks .....	12
4.8 Footrest Height Adjustment .....	13
4.9 Longitudinal (Forward /Backward) Position of Footplates .....	14
4.10 Lateral (Sideways) Position.....	14
4.11 Adjusting the Center of Gravity .....	15
4.12 Adjusting the Seat Height .....	15
4.13 Caster Angle Review .....	16
4.14 Backrest Height .....	17
4.15 Backrest Angle Adjustment.....	18
4.16 Flip Back and Height Adjustable Armrest.....	18
4.17 Upholstery .....	19

4.18 Anti-Tippers .....	19
4.19 Pelvic Belt (Option).....	20
4.20 How to Operate It:.....	21
4.21 Maintenance.....	21
4.22 Storing.....	21
4.23 Transferring In .....	22
4.24 Transferring Out .....	22
4.25 General Use.....	23
4.26 Tilting by the Attendant .....	25
4.27 Tilting by the User.....	25
4.28 Going Down Kerbs .....	25
4.29 Avoid Jarring the User .....	26
4.30 Going Up Kerbs .....	26
4.31 Going Up or Down Steps/Stairs.....	27
5. INSPECTION AND MAINTENANCE .....	27
5.1 Daily Check.....	27
5.2 Regular Maintenance Record .....	28
5.3 Adjustment Manual.....	31
6. OPTIONS AND ACCESSORIES .....	32
7. TROUBLESHOOTING.....	33
7.1 Trouble or Problems with Your Wheelchair .....	33
8. SPECIFICATIONS .....	34
9. CLEANING & RECYCLING.....	36
9.1 Cleaning.....	36
9.2 Post-Consumer Recycling .....	36
10. WARRANTY .....	37
10.1 Serial Number .....	37
10.2 Warranty Policy.....	37



---



# 1. PREFACE

Please carefully read this owner's manual before using the wheelchair. Improper use of the wheelchair could result in harm or injury. Therefore, for safe and enjoyable use of the wheelchair, please read this owner's manual.

1.1 This owner's manual includes operation instructions for the aspects of the wheelchair, unfolding/folding instructions and instructions on how to deal with possible accidents.

1.2 This owner's manual is written for KARMA wheelchair.

1.3 The symbols used in this manual are explained below. Pay special attention to the parts marked with these symbols.

	<b>WARNING:</b>	Improper use could lead the user to severe injury or death.
	<b>CAUTION:</b>	Improper use could lead the user to severe injury and/or damage to your wheelchair.
	<b>SUGGESTION:</b>	Follow these instructions to keep the wheelchair in good condition.

1.4 This manual includes the repair and maintenance chart as well as the warranty.

1.5 If someone else uses the wheelchair, make sure that you give him or her this owner's manual for his or her reference.

1.6 As designs change, some illustrations and pictures in this manual may not correspond to the wheelchair that you purchased. We reserve the right to make design modifications without further notice.

# 2. SAFETY

The user and attendant must be familiar with the operation of the wheelchair before using. Pedestrian traffic rules apply to the wheelchair. Please be safe. Please always keep these following safety guidelines in mind.

For a visually impaired people, be sure someone accompanies you in case you need assistance

The occupant shall have sufficient ability, functional capability, visual ability and cognizance to operate the wheelchair safely in its intended environment.

---

If not, do not drive it.

## 2.1 Doorways

The safest way to operate the wheelchair is on level floors that are free of obstacles. Whenever possible use a ramp to enter or exit a facility. Keeping your hands on the push rims will allow you to maintain maximum balance. Do not try to force yourself over an obstruction by propulsion and never use the sides of a doorway to pull yourself through a passageway.

## 2.2 Leaning

Do not lean over the side of your wheelchair since such an action may cause you to lose balance and fall. (See Figure 2.1.)

## 2.3 Negotiating Inclines

2.3.1 Never turn on a hill due to the danger of tipping.

2.3.2 When an attendant is pushing the wheelchair straight up a slope, if the user needs to go down midway on the slope, walk backwards until the user is on level ground. (See Figures 2.2 and 2.3)

2.3.3 Do not drive up to 7 degrees of incline to avoid danger. When negotiating inclines, don't propel up to 3 degrees of incline diagonally.

2.3.4 Avoid stopping on an incline, it can potentially cause you to lose control of the wheelchair.

2.3.5 Do not use the brakes to slow down or stop the wheelchair, this could cause it to seize up and make the user to lose control or fall out of the wheelchair.

2.3.6 Whenever possible, utilize help from an assistant/attendant while negotiating inclines.



### CAUTION:

- Although the product has met ISO 7176-1 requirements, we still recommend you not to drive on any slope (in any direction) greater than 7 degrees. If your daily activities require crossing slopes, we suggest you purchase and install anti-tippers to increase the stability of the wheelchair.

## 2.4 Kerbs

2.4.1 Whenever possible, get help from an assistant/attendant. If you have

---

assistance, make sure that your chair is equipped with push handles.

2.4.2 Avoid hard impacts when descending a kerb. A hard impact could adversely affect the wheelchair.

2.4.3 Never try to scale or descend kerbs that exceed a normal height.

2.4.4 Always take care when climbing kerbs or turning on slopes and never move in reverse without an assistant.

## 2.5 Stairs

2.5.1 Always use two or more assistants. Tilt the wheelchair to its point of equilibrium. One assistant (at the back) holds the wheelchair up against the first step, gripping the handles firmly to lift. The second assistant, holding firmly a fixed part of the front frame, lifts the wheelchair above the stairs and holds it while the first attendant places one foot on the following step and repeat the operation. (See below Figure)

2.5.2 Never go down steps forwards.

2.5.3 Never use an escalator for transport; use an elevator.

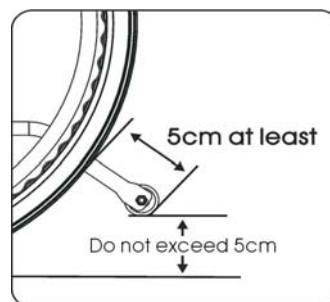

## 2.6 Streets

2.6.1 Always cross streets with great caution. Reflective tape on the wheelchair and/or your clothing will make you more visible to drivers.

2.6.2 Please comply with traffic safety code.

2.6.3 Avoid potholes and rough terrain that might cause the casters to become stuck. (See Figure 2.4)

## 2.7 General

2.7.1 Always make sure BOTH brakes are applied before getting in or out of the wheelchair.

2.7.2 Never stand on the footplates when getting in or out of the wheelchair.

---

2.7.3 Never carry more than one passenger. KARMA wheelchairs are limited to one single user.

2.7.4 Use caution to assure your clothing doesn't get tangled with the wheels.

2.7.5 When the user is operating the wheelchair using the pushrims, please push the wheelchair gently. DO NOT apply a sudden huge force on the pushrims. It could cause the chair to tip over. Please refer to the figure below for the best grip points for using the pushrims.



## 2.8 Upholstery

2.8.1 When cleaning the upholstery, use warm water and a mild soap.

2.8.2 Upholstery cleaner/foam can also be used, but avoid other cleaning solvents.

2.8.3 Do stay far away from any flame because it might injure the user and damage the wheelchair.

## 2.9 Anti-Tippers

Please strongly consider purchasing anti-tippers and always use them to avoid personal injury. The distance between the end of each anti-tipper and the rear wheel is at least 5cm; the distance to the ground is no more than 5cm.

## 2.10 Maximum User Weight Limit

Refer to "Max. Capacity" in section 8. SPECIFICATIONS. Loading exceeding maximum capacity can damage your wheelchair and cause malfunctions yielding a safety hazard. The warranty does not cover damage caused by improper operation of the wheelchair.

## 2.11 Avoid General Misuse

2.11.1 Please note that our "Owner's Manual" contains a number of cautions -- any vehicle can cause injury if misused -- use within our guidelines and with reasonable care and your safety will be increased. Your wheelchair will give years of safe use if used sensibly and carefully. Be aware that careless use endangers your own safety as well as that of others. ALWAYS follow the

---

Highway Code when outdoors and the guidelines written in this manual.

2.11.2 Do not let any child to stand or play on the wheelchair. (See Figure 2.5)



Figure 2.1



Figure 2.2



Figure 2.3



Figure 2.4



Figure 2.5

## 2.12 Circumstances to Avoid

2.12.1 Avoid roads with heavy traffic, mud, excessive gravel or bumps, snow and ice. These conditions may damage your wheelchair.

2.12.2 Avoid roads that are too narrow or by a canal/waterway without any fence/hedge.

2.12.3 Also avoid places where your wheels might get stuck, slip or not have traction.

2.12.4 Do not drive in a gale, at night or in rainy/snowy/foggy/misty weather. These conditions may cause your wheelchair to rust.

2.12.5 Do not drive in a S curve, do doughnuts or make sudden turns.

2.12.6 Do not take an escalator.

## 2.12 Labeling

Please carefully read all the labeling on the wheelchair before driving it. Do not remove them. Protect them for future reference.



1



2



3

Model:	
Order No.:	
Delivery Date:	
Sewing No.: <input type="checkbox"/> 1 <input type="checkbox"/> 2 <input type="checkbox"/> 3 <input type="checkbox"/> 4 <input type="checkbox"/> 5 <input type="checkbox"/> 6	
Seat Width	Seat Depth
<input type="checkbox"/> 13	<input type="checkbox"/> 13
<input type="checkbox"/> 14	<input type="checkbox"/> 14
<input type="checkbox"/> 15	<input type="checkbox"/> 15
<input type="checkbox"/> 16	<input type="checkbox"/> 16
<input type="checkbox"/> 17 <input type="checkbox"/> 0	<input type="checkbox"/> 17 <input type="checkbox"/> 0
<input type="checkbox"/> 18 <input type="checkbox"/> 5	<input type="checkbox"/> 18 <input type="checkbox"/> 5
<input type="checkbox"/> 19	<input type="checkbox"/> 19
<input type="checkbox"/> 20	<input type="checkbox"/> 20
<input type="checkbox"/> 21	<input type="checkbox"/> 21
<input type="checkbox"/> 22	<input type="checkbox"/>
<b>KARMA</b>	Unit: inch

4

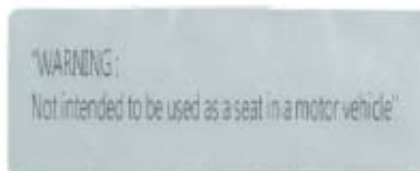

---

## 3. INTENDED USE & PARTS

### 3.1 Intended Use

- 3.1.1 The KM-9000 series with 24" rear wheels is a self-propelled wheelchair. It can either be pushed by an attendant or by the user.
- 3.1.2 This series of wheelchairs are suitable for a single user up to 125kg in weight. Hand brakes are provided for both rear wheels.
- 3.1.3 It is equipped with pneumatic tires for traction and comfort. It also has an extremely durable aluminum alloy frame with tough accessories and does not deteriorate when exposed to extreme temperature (neither the user nor the attendant need to touch any metal part in normal use.)
- 3.1.4 This wheelchair is designed for both indoor and outdoor use.
- 3.1.5 The casters have PU tires for greater durability; pneumatic casters are available on request.
- 3.1.6 The rear wheels are 24 inches in diameter and the tire pressure must be kept at 100-110 PSI (7.0-7.5BAR).
- 3.1.7 KM-9000 system provides pressure relief, stabilization and reduced sliding.

### 3.2 KM-9000 with 24" Rear Wheel Parts Description



- |                        |                |
|------------------------|----------------|
| 1. Push Handle         | 8. Side Panel  |
| 2. Backrest Upholstery | 9. Seat Sling  |
| 3. Handrim             | 10. Rear Wheel |
| 4. Quick-Release Axle  | 11. Cross Bar  |
| 5. Brake               | 12. Footrest   |
| 6. Fork                | 13. Footplate  |
| 7. Caster              |                |



---

## 4. OPERATION

The Ergo Live Series is a self-propelled or transit wheelchair. That is, it can either be operated by the user (self-propelled) or by an attendant.



### CAUTION:

- Your wheelchair should be adjusted by your authorized KARMA dealer. Your authorized KARMA dealer is also your service provider. Anything wheelchair related that requires tools should be done by your authorized KARMA service provider. Your KARMA service provider has the necessary service/maintenance manual for your wheelchair.

Preparing For Use

### 4.1 Unfolding

4.1.1 Holding the armrests, push outwards. (See Figure 4.1)

4.1.2 Pointing your fingers inward with the palm of your hand on the frame, push down until the seat is fully lowered. Make sure the frame is firmly seated in its holder. (See Figure 4.2)

4.1.3 Flip the footplates down. (See Figure 4.3)

4.1.4 Ready to use!

Alternatively, you can stand at the side of the wheelchair and complete step 1 by pulling the nearest armrest towards yourself and pushing the other one away.



Figure 4.1

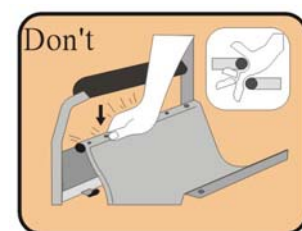

Figure 4.2



Figure 4.3

While completing step 2, never put your fingers around the sides or under the wheelchair as they can be trapped between the seat and the frame. (See the right figure.)



---

## 4.2 Folding

4.2.1 Flip up the footplates. (See Figure 4.4)

4.2.2 Pull up by holding the center of the seat. (See Figure 4.5)

4.2.3 Folding is now completed. (See Figure 4.6)



Figure 4.4



Figure 4.5



Figure 4.6



### CAUTION:

- Be careful not to get your fingers caught when folding the wheelchair.

## 4.3 Getting Into Your Wheelchair (See Figure 4.7)

4.3.1 Push the wheelchair against a wall or a solid piece of furniture.

4.3.2 Apply the brakes

4.3.3 Flip the footplates up

4.3.4 The user lowers the body and sits on the wheelchair gently.

4.3.5 Fold down the footplates and position your feet in front of the heel loops.

4.3.6 Release the brakes.

## 4.4 Getting Out of Your Wheelchair (See Figure 4.8)

4.4.1 Apply the brakes.

4.4.2 Up move the feet away from the footplates and fold up the footplates.

4.4.3 With one hand on the armrest, the person should bend slightly forward, to bring the body weight to the front of the seat, and then with both feet firmly on the ground and one foot behind the other, push up into the upright position.



Figure 4.7



Figure 4.8

## 4.5 Rear Wheel Disassembly

Quick release rear wheels are optional. If your wheelchair is equipped with quick release rear wheels, please follow these instructions as listed below.

4.5.1 Support the weight of the chair with one hand by holding the push handle. The weight of one rear wheel set could up to 2kg.

4.5.2 Dress the hub cover and pull out the rear wheel.

4.5.3 Remove the rear wheel. (See Figure 4.9)

## 4.6 Rear Wheel Assembly

4.6.1 First ensure that the brake is in the OFF position.

4.6.2 Take up the wheel with axle and press the hub cover in the centre of the axle, as above.

4.6.3 This retracts the ball bearings that will allow you to push the axle into the wheel bracket that is located on the lower rear frame of the wheelchair.

4.6.4 When you remove your thumb from the button on the axle, the ball bearings should be visible protruding from the axle at the back of the wheel bracket. This will secure the wheel safely in the frame. (See Figure 4.10).

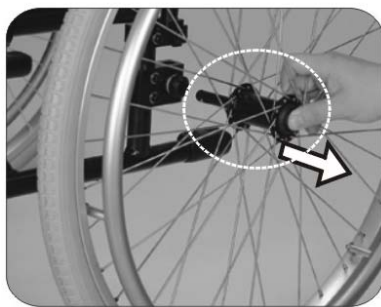

Figure 4.9

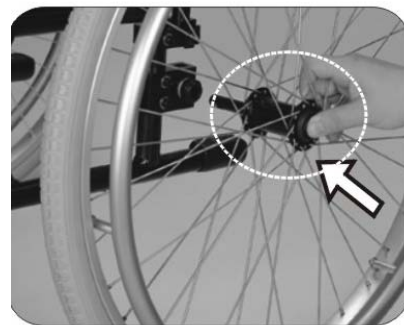

Figure 4.10



## CAUTION:

- You must make sure that the axle is fully located in the wheelchair bracket and that the ball bearings are fully open and have positively attached the wheel in the frame.
- The rear wheel can be mounted at different positions on the frame to alter the seat height and overall stability of the chair. Changing the wheel position should be carried out by your approved repairer or therapist.

## 4.7 Wheel Locks

Your wheelchair is equipped with two wheel locks

4.7.1 They are applied directly against the tires. Push the handle of wheel-lock forward to engage and pull the handle of wheel-lock to release.

4.7.2 Braking could be less efficient due to:

4.7.2.1 Worn tire tread

4.7.2.2 Low tire pressure

4.7.2.3 Wet tires

4.7.2.4 Improper wheel locks adjustment.

4.7.3 The wheel locks are not designed to be used for a moving wheelchair.

4.7.4 Always use the handrims for braking. Make sure that the interval between the tires and wheel locks complies with the given specifications.

(See Figure 4.11)

4.7.5 To re-adjust, loosen the screw and set the appropriate gap. Then re-tighten the screw. (See Figure 4.12)



Figure 4.11

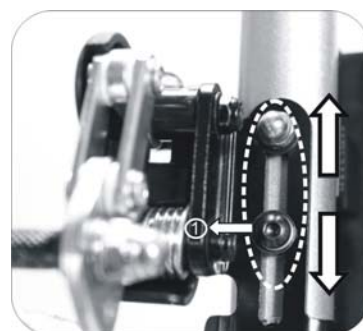

Figure 4.12



**CAUTION:**

- After each adjustment of the rear wheels, check the wheel-lock gap and re-adjust if necessary.

## 4.8 Footrest Height Adjustment

To adjust the footplate height, follow the instruction as listed below:

4.8.1 Loosen the screw on footplate. (See Figure 4.13)

4.8.2 Adjust footrest height to make the user's thighs be parallel to the ground or feel comfortable.

4.8.3 Adjust footplate angle until it is parallel to ground or comfortable. (See Figure 4.14&4.16)(Two-Piece Type Footplate No such function)

4.8.4 To adjust footplate height, use the Karma tool provided to loosen the bolt at the end of the footrest arm. (See Figure 4.15)

4.8.5 Adjust it to the desired angle and re-tighten. (See Figure 4.13)



Figure 4.13



Figure 4.14



Figure 4.15



Figure 4.16



**CAUTION:**

- Make sure that the footplate height is adjusted properly according to the user's calf length to reduce pressure on the body.
- The footrest height must be more than 5cm.
- If difficulty arises in adjusting footrest height, further loosen the fastening screw.



Figure 4.17



Figure 4.18

#### 4.9 Longitudinal (Forward /Backward) Position of Footplates

To accommodate the user's leg position and flexibility, follow the instruction as listed below: (Two-Piece Type Footplate No such function)

4.9.1 Remove the footplate fastener bolts on each plate.

4.9.2 Adjust the footplate to the desired position.

4.9.3 Re-tighten the footplate fastener bolts. (See Figure 4.19)

#### 4.10 Lateral (Sideways) Position

To open or close the gap between the footplates, follow these instructions as listed below: (Two-Piece Type Footplate No such function)

4.10.1 Loosen the footplate fastener bolts on each plate.

4.10.2 Adjust the footplate to the desired position.

4.10.3 Re-tighten the footplate fastener bolts. (See Figure 4.20)



Figure 4.19



Figure 4.20

---

## 4.11 Adjusting the Center of Gravity

There are three positions of center of gravity including: front, middle, and rear

4.11.1 Release the rear wheel. (See Figure 4.21)

4.11.2 Use the tool to loosen the bolt on the plate (See Figure 4.22)

4.11.3 Select the position that suits your needs. (See Figure 4.23)

4.11.4 Insert the rear wheel axle housing into the selected position and tighten it.

Make sure the nut is fully tightened. (See Figure 4.24)

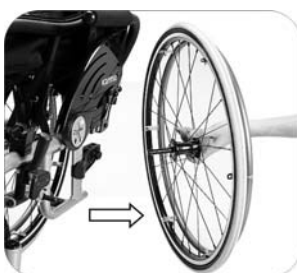

Figure 4.21



Figure 4.22



Figure 4.23



Figure 4.24



### CAUTION:

- For your safety, when you use the wheelchair for the first few times, Karma strongly recommends you to use the rear position which provides the maximum axle distance. The setting will help you to avoid potential dangers until you are fully comfortable with your wheelchair. Once you are comfortable with the setting, you can shorten the distance between the front and rear wheels according to your demand.

## 4.12 Adjusting the Seat Height:

There are four levels adjustments.

4.12.1 Release the rear wheel. (See Figure 4.25)

4.12.2 Use the tool to loosen the screw on the plate. (See Figure 4.26)

4.12.3 Adjust upward or downward to your desired height. (See Figure 4.27)

4.12.4 Re-tighten the screw to complete the seat height adjustment.

4.12.5 The front caster position must correspond to the rear wheel height. Please refer to 5.5 for further adjustment. (See Figure 4.28)





Figure 4.25



Figure 4.26

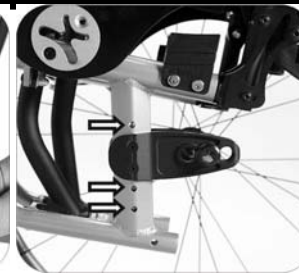

Figure 4.27



Figure 4.28



**CAUTION:**

- The adjustment is in increments of 12.7mm for the front casters, and 22mm for the rear wheels.
- Seat height adjustment can be done with other front wheel size.

### 4.13 Caster Angle Review

Please put the wheelchair on a flat table while adjusting in order to ensure the accuracy.

4.13.1 Make sure the caster adapter is 90 degrees to the ground.

4.13.2 Once you adjust the seat height, front caster, rear wheel and the center of gravity position, please make sure the caster adapter is 90 degrees to the ground.

4.13.3 Rotate both forks so that the casters are towards the rear of the wheelchair. Place a square or pocket level against the flat surface on the rear of the fork and note whether this surface is vertical. If this surface is more than 2 degrees away from vertical, your casters require re-squaring. (See Figure 4.29)

4.13.4 Use the tool to loosen the screws and nuts on the caster adapter. (See Figure 4.30)

4.13.5 Adjust the caster adapter to 90 degrees toward the ground.

4.13.6 Place a square or pocket level against the flat surface on the rear of the fork and note whether this surface is vertical. (See Figure 4.29)

4.13.7 Place the eccentric hexagonal pads in the appropriate direction, and lock the screws and nuts of the front caster adapter. (See Figure 4.31)





Figure 4.29



Figure 4.30



Figure 4.31

## 4.14 Backrest Height

To adjust the backrest height, follow these instructions as listed below:

4.14.1 Use the tool provided by KARMA to loosen the screws at the both bottom sides of the backrest frame. (See Figure 4.32)

4.14.2 Adjust the backrest to the desired height. (See Figure 4.33)

4.14.3 Tighten the screws, attach the armrest and backrest upholstery to the original condition.

4.14.4 Backrest height adjustment is now completed. (See Figure 4.34)



Figure 4.32



Figure 4.33



Figure 4.34

---

## 4.15 Backrest Angle Adjustment

To adjust the backrest angle, follow the instruction as listed below:

4.15.1 Use the tool provided by KARMA to loosen and remove the screws at the both bottom sides of the backrest frame. (See Figure 4.35)

4.15.2 Adjust the backrest forward or backward to the position as desired. (  $-5^{\circ}$  、  $0^{\circ}$  、  $5^{\circ}$  ) (See Figure 4.36)

4.15.3 Tighten the screw and put armrest and backrest cushion back to the seat.

4.15.4 Backrest angle adjustment is now completed.



Figure 4.35

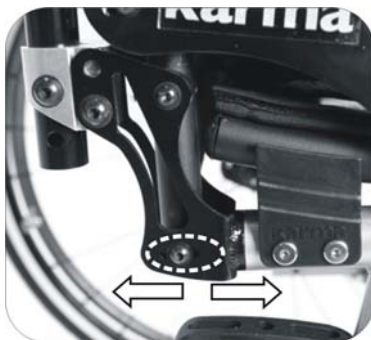

Figure 4.36

## 4.16 Flip Back and Height Adjustable Armrest

Hold the front of the armrest and pull backward to flip back the armrest.

4.16.1 Release the rear wheel. (See Figure 4.38)

4.16.2 Use the tool to loosen the screw on the armrest tube to adjust the armrest height. (See Figure 4.39)

4.16.3 Adjust upward or downward to the desired height. (See Figure 4.40)



Figure 4.37

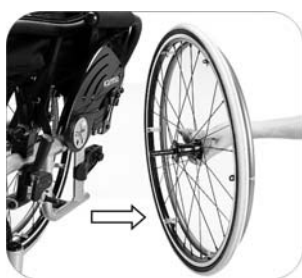

Figure 4.38



Figure 4.39



Figure 4.40

## 4.17 Upholstery

When upholstery is loose, you can tighten it which by pulling and re-attaching the Velcro. (See Figure 4.41 and Figure 4.42)



Figure 4.41



Figure 4.42

## 4.18 Anti-Tippers

The main purpose of anti-tippers is to prevent the user from turning over.

4.18.1 When you install the anti-tippers, if the anti-tippers are adjustable, please make sure the distance between the end of each anti-tipper and the rear wheel is at least 5cm; the distance to the ground does not exceed 5cm. (See Figure 4.43)

4.18.2 The release pin should be protrudent once you have installed the anti-tippers. Please try to pull forward and backward to check if the anti-tippers are immovable. (See Figure 4.44)

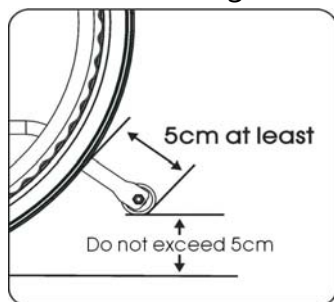

Figure 4.43



Figure 4.44



### CAUTION:

- If the anti-tip tubes are not fitted, or have been fitted incorrectly, there is a risk of tipping over and of injury.

## 4.19 Pelvic Belt (Option)

4.19.1 Please follow the instruction to use the pelvic belt for your safety.

4.19.2 Please follow the instruction to assemble or disassemble the pelvic belt.

4.19.3 Put both ends of the pelvic belt straight through the backrest holder and insert it through the buckle to adjust to the desired length. (Figure 4.45)

4.19.4 The most comfortable way of using the pelvic belt is to keep it as 45 degrees. (Figure 4.47)



Figure 4.45



Figure 4.46

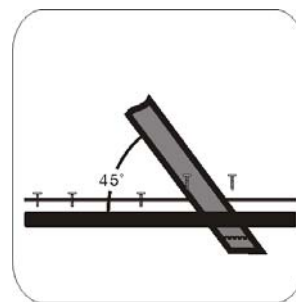

Figure 4.47

4.19.5 Please follow the instruction to adjust the pelvic belt.

4.19.6 Make sure that the total length of the pelvic belt is sufficient.

4.19.7 Adjust the length of the pelvic belt through the buckle of both ends. (Figure 4.48)

4.19.8 Pull the two parts of belt tight. (Figure 4.49)

4.19.9 Push the buckle of both ends to the plastic clip so that the pelvic belt will not slip out of the position. (Figure 4.50)



Figure 4.48



Figure 4.49



Figure 4.50



### SUGGESTION:

- Please kindly be advised that the pelvic belt should be fitted tightly around the pelvis and be tightened until you can just get one finger through between the pelvic belt and the user. Kindly check the pelvic belt position is fitted to the place as we recommend. If it is not able to be this way, please consult your supplier.



#### CAUTION:

- **Maintenance:** There is no specific maintenance for the pelvic belt; however, please check if the edge of the pelvic belt is worn or torn before you use it. Meanwhile, please adjust the pelvic belt properly to fit the user. If the pelvic belt is damaged, please replace a new one immediately.

### 4.20 How to Operate It:

4.20.1 When you sit on the wheelchair, fasten the pelvic belt.

4.20.2 Adjust the belt and make it fit your body for comfort and security.

4.20.3 When you don't use it, please fasten the belt to avoid the belt dropping into the rear wheels during motion.

### 4.21 Maintenance

The pelvic belt is made from 100% polyester fiber and the clasp is made from plastic. It does not require any maintenance but should be inspected every month to ensure that the edges are not frayed and weekly to make sure that it correctly fits the user. If there are any signs of deterioration, please replace it immediately.

### 4.22 Transport and Storage

Make sure that the wheelchair is fully folded when it is in transport or storage.

When loading or moving the wheelchair in a vehicle, be sure that every part that have been detached from the wheelchair is placed properly to prevent them from moving. It could damage the vehicle or the wheelchair.



#### SUGGESTION:

- Please store the wheelchair in a location where it is out of direct sunlight, rain and dew. For more details, consult your KARMA dealer.



#### WARNING:

- Don't put anything on the wheelchair while it is in storage. Storing goods on a folded or unfolded wheelchair will cause damage and is not covered under warranty. (See the right figure.)



---

## 4.23 Transferring In

### 4.23.1 Transferring In

4.23.2 Engage both hand brakes.

4.23.3 Turn the footplates up and swing them to the side.

4.23.4 Lower the user into the seat, allowing them to use the armrests for support.

4.23.5 Turn the footplates back down, so that the user can place his feet on them.

Ensure that the heels rest against the heel supports to prevent contact with the casters.

4.23.6 Release both hand brakes.



#### CAUTION:

- **Always ensure that the front casters are in line with the rear wheels and pointing forwards and that the back of the chair is secure either against a wall or firmly held by an attendant.**

## 4.24 Transferring Out

4.24.1 Make sure that the chair is near your final destination.

4.24.2 Move the wheelchair backwards so that the casters are pointing forwards and are in line with the rear wheels

4.24.3 Ensure that, where possible, the rear of the chair is against a wall or, if not, it must be firmly held by an attendant.

4.24.4 Engage both hand brakes.

4.24.5 Turn the footplates up and swing them to the side.

4.24.6 Slide forwards on the seat. Place one foot firmly on the ground with the knee at a right angle and the other foot slightly apart and further back.

4.24.7 Place your hands on the front of the armrests and moving your weight forward, bring your head and shoulders up over your knees as you push yourself up.

4.24.8 Some people have to side transfer.

4.24.9 Flip back your armrest, and make sure that the chair is close to the place you are transferring to.

4.24.10 Prop up your body and move sideward slowly, using transfer board. Be careful not to hit the brake or other components of wheelchair.



## CAUTION:

- Never stand on the footplates when getting into (or out of) the chair. (See Figure 4.51).
- When getting in and out of the wheelchair please use the hand brakes. The hand brake is the lever at the side of the wheelchair.
- Please ensure that neither the tread on your tires nor the brake block has become too worn. If pneumatic tires are fitted, please maintain at the recommended tire pressure for the same reason.
- Please ensure that occupant's fingers do not get caught in the brake.

When transferring in and out of the chair, make sure that the brakes are applied to prevent the chair from sliding away. Also see that the footplates are flipped up for ease of entering or exiting. (See Figure 4.52)

## 4.25 General Use

### 4.25.1 Attendant Pushing and Self Propelling

4.25.1.1 Ensure that the brakes are always locked when the chair is not being pushed. (See Figure 4.53)

4.25.1.2 Always make sure that both feet are safely on the footplates and that clothing is safely tucked out of the way and cannot get caught in the wheels. (See Figure 4.54)

4.25.1.3 Always use both hands on the push handles to control the chair. (See Figure 4.55)

4.25.1.4 Always avoid steep or uneven surfaces because the chair may tip over. (See Figure 4.56)

4.25.1.5 Always avoid soft surfaces because the casters may get bogged down. (See Figure 4.57)

4.25.1.6 Always be careful not to go too fast or turn too quickly and try to achieve a smooth steady ride.

4.25.1.7 Before crossing the road, please stop completely and look both ways.

4.25.1.8 Cross tracks or ruts at right angles to avoid your casters getting stuck.

4.25.1.9 Do not drive at full speed over the railroad tracks.

4.25.1.10 DO NOT sit in the wheelchair within a moving vehicle unless it has been affixed the labels of hook mark.

4.25.1.11 Please keep your hands and arms inside the wheelchair when going



through doorways.



**WARNING:**

- The wheelchair cannot be used as seats in any vehicles. That is, KARMA recommends that users are NOT transported in any vehicle while seated in the wheelchair. In the case of accident or a sudden stop, the user could be thrown from the wheelchair and get injured. The suggested solution is to transfer the user from the wheelchair into a normal seat of the vehicle and to securely stow the wheelchair in a separate compartment.

PLEASE keep in contact with the person in the chair. If you stop to look in shop windows or talk to people, remember to turn the chair so that the person in the chair does not have to turn.



**WARNING:**

- NEVER lock the brakes too quickly as this may tip the user out of the wheelchair.



Figure 4.51



Figure 4.52



Figure 4.53



Figure 4.54



Figure 4.55



Figure 4.56



Figure 4.57



Figure 4.58



---

## 4.26 Tilting by the Attendant

4.26.1 Make sure both the user's feet are on the footplates and will not slip off.

Make sure the handgrips are secure and cannot slip off.

4.26.2 Release both brakes.

4.26.3 Grasp both push handles firmly.

4.26.4 Put your stronger foot on the relevant tipping lever at the back of the wheelchair.

4.26.5 Tell the person in the wheelchair that you are about to tilt the wheelchair backwards.

4.26.6 Pull back with both hands and push down and forwards with the foot. This will bring the wheelchair onto the back wheels. (See Figure 4.58)



### CAUTION:

- When a wheelchair is tilted to about 25 degrees it will balance on the rear wheels and be easy to hold. If it is tilted further back it will be difficult to hold and the person in the wheelchair will feel unsafe.
- Lower the wheelchair with your back straight, keep your foot on the anti-tipper and lower the wheelchair slowly forwards softly to the ground.

## 4.27 Tilting by the User

4.27.1 Make sure your feet are on the footplates and will not slip off.

4.27.2 Release both brakes.

4.27.3 Grasp both handrims and give a firm, sudden forward push immediately before the obstacle, continue the momentum (be ready to keep pushing) until the obstacle is mounted.



### CAUTION:

- This method should only be attempted by people experienced in wheelchair use. Sufficient muscle strength is also necessary. It is always better to have the help of an attendant.
- Leaning backwards causes the caster to rise higher BUT it is much safer to lean forwards and stay balanced.

## 4.28 Going Down Kerbs

Please note: It is always better to avoid kerbs where possible by using ramped kerbs or slopes and this operation is best attempted with the aid of an attendant.

---

#### 4.28.1 Going Down Kerbs Forwards With an Attendant



##### CAUTION:

- This is the more difficult method and can jar the user but allows a better view of traffic.
- Be careful that the anti-tipper does not get caught on the kerb causing the user to fall.
- **NEVER ALLOW THE WHEELCHAIR TO TIP FORWARDS WHEN GOING DOWN A KERB.**

4.28.2 Position the wheelchair so that the front casters are near the edge of the kerb and make sure that the road is clear

4.28.3 Move the wheelchair slowly and carefully forwards while tilting it back slightly. Be ready to take the weight when the rear wheels cross the kerb edge. Ensure that both rear wheels touch the ground at the same time to avoid tipping the wheelchair

4.28.4 Gently lower the front casters.

#### 4.29 Avoid Jarring the User

##### 4.29.1 Going Down Kerbs Backwards With an Attendant



##### CAUTION:

- **This is the easier and smoother method BUT it requires the attendant to step backwards into the road.**

4.29.2 Back the wheelchair to the kerb edge and be careful that the back wheels are equally near the edge.

4.29.3 Grasping the push handles, gently lower the rear wheels onto the road. Be prepared to control the weight as it descends and ensure that the back wheels touch ground at the same time.

4.29.4 Tilt the wheelchair back slightly and pull the tilted wheelchair far enough into the road so that the casters and footrests can be lowered clear of the kerb.

#### 4.30 Going Up Kerbs

Please note: This operation is best attempted with the aid of an attendant and the best method is to go up kerbs forwards as this maintains the direction of travel and is physically less demanding for the attendant.

---

#### 4.30.1 Going Up Kerbs Forwards With an Attendant

4.30.2 As the footrests nearly touch the kerb tilt the wheelchair. The wheelchair should be tilted just high enough to allow the front casters to roll smoothly onto the pavement.

4.30.3 Push the wheelchair forward until the rear wheels are touching the kerb. Then, continuing the movement, lift at the push handles while moving the wheelchair forwards.

#### 4.30.4 Going Up Kerbs Backwards With an Attendant

Please note: for safety's sake we do not recommend using this method.

### 4.31 Going Up or Down Steps/Stairs

4.31.1 Please note: avoid flights of steps particularly if no extra help is available. Use ramps or lifts wherever possible.

4.31.2 Two attendants are necessary, each capable of carrying at least half of the combined weight of the person and the wheelchair.

4.31.3 Each helper should bend at the knees and grip the main frame: with the front attendant's hands just under the front of the seat, with the back attendant's hands holding the frame just under the push handles.



#### CAUTION:

- **Never hold on to movable or detachable parts.**

ALL LIFTING SHOULD BE DONE WITH A STRAIGHT BACK.

Straighten legs to lift the wheelchair. Carefully carry it up or down steps; be aware of how you place your feet -- do not cross them and trip yourself up.

## 5. INSPECTION AND MAINTENANCE

### 5.1 Daily Check

Check the following items before traveling. If you find anything abnormal, visit your KARMA wheelchair dealer for further inspection before using it.

5.1.1 Examine the brakes and check for any wear, damage and misalignment. Replacing or adjusting the brakes should be carried out by your approved repairer.

5.1.2 Check that the handgrips are not damaged and are securely bonded to the

push handles.

5.1.3 Check anti-tippers are not damaged and are securely attached.

5.1.4 Check that the anti-tippers' wheels and frame are not damaged and are securely mounted.

5.1.5 Before using the wheelchair, make sure all nuts and bolts are tight. Check all parts for damage or wear and have a qualified technician replace it if necessary. Check all parts for proper adjustment. Inspect brakes for proper operation.

5.1.6 The wheels and tires should be checked periodically for cracks and wear, and should be replaced by a qualified technician.

5.1.7 A qualified technician can be found at an authorized distributor/dealer.

 <b>CAUTION:</b>
● Visit a KARMA wheelchair dealer for inspection and maintenance if you find anything abnormal.

## 5.2 Regular Maintenance Record

To make sure your wheelchair is in good condition, visit your KARMA wheelchair dealer regularly for maintenance (and keep records accordingly) every six months after purchasing.

A maintenance/service fee may apply.

 <b>WARNING:</b>
● Even if you don't use the vehicle for a long time, the wheelchair should still be maintained regularly. You should clean your wheelchair regularly.

Item	Weekly	Monthly
● <b>GENERAL</b>		
● The wheelchair rolls straight (no excessive drag or pull to one side)		V
● <b>FRAME AND CROSS BARS</b>		
● Inspect the frame structure for any small cracks/fissures		V
● Inspect for any bent frame or cross bars		V
● <b>BRAKES</b>		

● Do not interfere with the tires when rolling		V
● Pivot points are free of wear and looseness		V
● Easy to engage	V	
● Make the wheelchair stop from moving when engaged	V	
● <b>SEAT &amp; BACKREST</b>		
● Inspect for any rips or sagging	V	
● Inspect for any loose or broken hardware		V
● <b>CASTERS</b>		
● Inspect the casters for smooth rotation of the caster wheels and caster assembly		V
● Inspect the casters for any wear in the bearings/mountings and for tire wear or damage		V
● <b>REAR WHEELS</b>		
● Quick-release axles lock properly; lubricate if necessary	V	
● No excessive side movement or binding when lifted and spun		V
● Inspect for any cracked, bent or broken spokes	V	
● <b>ARMRESTS</b>		
● Inspect the detachable armrest button for effective locking		V
● Make sure the armrest detaches and flips back properly		V
● <b>FOOTRESTS</b>		
● Inspect the footplate height adjustment screws are securely tightened		V
● Inspect the swing-away footrest release lever for effective locking		V
● <b>TIRES</b>		
● Inspect for flat spots, cracks and wear	V	
● Check that tire tread depth is more than 1mm		V
● For pneumatic tires, check for proper inflation; tire pressures are specified on the side of the tire	V	



**CAUTION:**

- If you find anything abnormal, stop using the wheelchair immediately and visit a KARMA wheelchair dealer for inspection and maintenance.
- As with any wheelchair, the wheels and tires should be checked periodically for cracks and wear, and should be replaced. Failure to keep tires at the correct pressure will reduce the braking efficiency.
- Never disassemble or modify the wheelchair frame structure. Otherwise, injury or damage may occur. This will void the warranty.

## 5.3 Adjustment Manual

### 5.3.1 Seat Height Adjustment

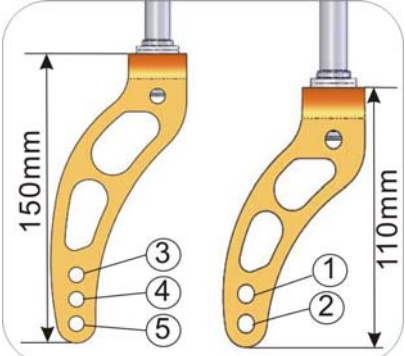
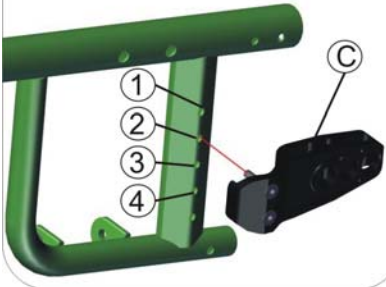
Caster/ Rear Wheel	■ 24" (diameter)x 1"(width)				Caster Position 
	□ 5" Caster		□ 6" Caster		
	110mm Caster Fork	150mm Caster Fork	110mm Caster Fork	150mm Caster Fork	
Seat Height					
17.5" (445mm)	□ B-2 C-1				Caster Fork 
18" (457mm)	□ A-2 C-1				
18.5" (470mm)		□ A-3 C-2	□ A-2 C-2		
19" (483mm)				□ A-3 C-3	
19.5" (495mm)		□ A-5 C-3		□ A-4 C-3	
20" (510mm)				□ A-5 C-4	

## 6. OPTIONS AND ACCESSORIES

 A black, curved metal anti-tipper device with a gold-colored tip and a black handle.	 A black fabric bag with a pocket, attached to the backrest of a wheelchair. The bag has the KARMA logo on it.
<ul style="list-style-type: none"><li>● Anti-Tipper<ul style="list-style-type: none"><li>- Attaches to all KARMA manual wheelchairs</li></ul></li></ul>	<ul style="list-style-type: none"><li>● Backrest Bag<ul style="list-style-type: none"><li>- Standard size</li><li>- Attaches to all KARMA manual wheelchairs</li></ul></li></ul>



### CAUTION:

- Attaching accessories may alter the overall stability and center-of-gravity of the chair. Thus, this should be performed by your approved repairer and therapist.



---

## 7. TROUBLESHOOTING

### 7.1 Trouble or Problems with Your Wheelchair

You can inspect the following before taking your wheelchair to a KARMA wheelchair dealer.

Problem	Checking Points and Corrective Action
1. Wheelchair Veers Right/Left	<ul style="list-style-type: none"><li>● Check tires for correct and equal pressure</li><li>● Check caster bracket angle</li><li>● Check that rear wheels are equally spaced from the seat frame</li></ul>
2. Sluggish Turn or Performance	<ul style="list-style-type: none"><li>● Check tires for correct and equal pressure</li><li>● Check for loose nuts and bolts</li></ul>
3. Caster Flutter/Wobble	<ul style="list-style-type: none"><li>● Check tires for correct and equal pressure</li><li>● Check for loose nuts and bolts</li><li>● Check caster bracket angle</li></ul>
4. Squeaks and Rattles	<ul style="list-style-type: none"><li>● Check for loose nuts and bolts</li></ul>
5. Looseness in Wheelchair	<ul style="list-style-type: none"><li>● Check for loose nuts and bolts</li></ul>

If you cannot solve the problem by yourself, contact your KARMA wheelchair dealer for help.

## 8. SPECIFICATIONS

( ±5mm, ±0.5kg )

Model	ERGO LIVE (KM-9000)			
Rear wheel	24"			
Frame Color	Lime Green 、Tango Orange 、Bright White			
Seat/Backrest Upholstery Cover Color	Black upholstery/Black cushion			
Seat Width/Depth	14"*15"	14"*16"	16"*16"	18"*16"
Caster/ Rear wheel	5" x 24"			
Brakes	Parking Brake			
Overall Length (mm)	890 mm			
Overall Width (mm)	509 mm	509 mm	560 mm	610 mm
Overall Height (mm)	850 mm			
Seat Width (mm)	356 mm(14")		410 mm(16")	458 mm(18")
Seat Depth (mm)	380 mm(15")	406 mm(16")		
Seat Height (mm)	470mm(18.5")			
Backrest Height(mm)	406 mm(16")			
Armrest Height (mm)	225 mm/250 mm			
Calf Length (mm)	360 mm/380 mm/400 mm/420 mm/440 mm (Adjustable)			
Footplates	Adjustable Aluminum Footplate/ Adjustable Aluminum Flip-Up Footplates / Two-Piece Type Footplate			
Folding L*W*H(mm)	890 mm*325 mm*850 mm			
Seat/Back Angle	5°			
Max. Safe Slope (X°)	10°			
Reversing Width (mm)	820mm			
Total Weight (kg)	11.7 ( ±0.5 ) kg		11.8 ( ±0.5 ) kg	
Maximum User Weight (kg)	125 kg / 90 kg( <b>Two-Piece Type Footplate</b> )			
Packing Size (mm)	910 mm*345 mm*875 mm		910 mm*345 mm*875 mm	

Use Two-Piece Type Footplate , the Maximum safe load is 90 kg.

KARMA reserves the right to modify information herein without further notice.

Product specification could be varied according to customer requirements.

( ±5mm, ±0.5kg )

Model	ERGO LIVE (KM-9000)	
Rear wheel	24"	
Frame Color	Lemon Yellow · Diamond Black · Fashion White	
Seat/Backrest Upholstery Cover Color	Black upholstery/Black cushion	
Seat Width/Depth	16"*18"	18"*18"
Caster/ Rear wheel	5"x 24"	
Brakes	Parking Brake	
Overall Length (mm)	941 mm	
Overall Width (mm)	560 mm	610 mm
Overall Height (mm)	850 mm	
Seat Width (mm)	410 mm(16")	458 mm(16")
Seat Depth (mm)	458 mm(18")	
Seat Height (mm)	470 mm(18.5")	
Backrest Height(mm)	406 mm(16")	
Armrest Height (mm)	225 mm/250 mm	
Calf Length (mm)	360 mm/380 mm/400 mm/420 mm/440 mm (Adjustable)	
Footplates	Adjustable Aluminum Footplate/ Adjustable Aluminum Flip-Up Footplate / Two-Piece Type Footplate	
Folding L*W*H(mm)	941 mm*325 mm*850 mm	
Seat/Back Angle	5°	
Max. Safe Slope (X°)	10°	
Reversing Width (mm)	820mm	
Total Weight (kg)	11.9 ( ±0.5 ) kg	
Maximum User Weight (kg)	125 kg / 90 kg( <u>Two-Piece Type Footplate</u> )	
Packing Size (mm)	960 mm*345 mm*950 mm	

Use Two-Piece Type Footplate , the Maximum safe load is 90 kg.

KARMA reserves the right to modify information herein without further notice.

**Product specification could be varied according to customer requirements.**

### Static Stability Test of Ergo Live Series (According to ISO 7176-1:1999)

Forward Max. 10 degrees

Backward Max. 10 degrees

Sideways Max. 17 degrees

- The degree tolerance is +0, -1 degree.
- The test condition: size of test dummy used 125 kg.



#### CAUTION:

- Please don't travel across a slope (in any direction) greater than 7 degrees.

## 9. CLEANING & RECYCLING

### 9.1 Cleaning

In order to lengthen the life of your wheelchair, it is suggested that you clean the wheelchair periodically (if not daily), especially after it is used in the rain or snow. We suggest that you don't use your wheelchair in the rain or snow. If you are traveling and get caught in the rain, we suggest you try to find a shelter while waiting it out. If you can't find any shelter, proceed to your destination.

#### 9.1.1 Frame

Wipe with a damp cloth.

#### 9.1.2 Upholstery

9.1.2.1 When cleaning the upholstery, use warm water and a mild soap.

9.1.2.2 Upholstery cleaner/foam can also be used, but avoid other cleaning solvents.

### 9.2 Post-Consumer Recycling

A post-consumer recycling plan should follow the Environmental Protection Administration's regulations. The items listed below are for reference only as local laws and regulations may vary.

Material	Part Name	Method
Aluminum-alloy	Frame	Recyclable
Plastic	Modular Components	Recyclable
Paper	Owner's Manual	Recyclable

9.2.1 There are organizations in many countries you can find on the Internet that will

---

accept used goods for charity. Please search the information highway to help less fortunate individuals and protect our planet for future generations. If you do not have access to the world wide web please use your local phone directory, ask for operator assistance or go to your local government center for more information. Earth Day is every day.

9.2.2 Check with your local recycling center on where and how to recycle your wheelchair as this information varies from region to region.

## 10. WARRANTY

### 10.1 Serial Number

To ensure after-sale service and warranty, please record and fill in the serial number which can be found on the frame.

Model	
Serial Number	

### 10.2 Warranty Policy

#### 10.2.1 Contents and Duration of Warranty

10.2.1.1 Repair will be provided free of charge if the problems are due to manufacturing or defective components within the warranty period (a repair of this kind will hereafter be called warranty repair).

10.2.1.2 Warranty repairs can be performed by authorized KARMA wheelchair dealers only.

10.2.1.3 KARMA is not responsible for the transportation costs for repair and replacement.

10.2.1.4 Replaced parts will be the property of KARMA.

---

## 10.2.2 Items Not Covered by Warranty

- 10.2.2.1 Irregularities that do not affect function and safety of product.
- 10.2.2.2 Damage resulting from normal wear and tear.
- 10.2.2.3 Problems arising due to lack of basic maintenance and self-inspection.
- 10.2.2.4 Damage resulting from use not following operation guidelines.
- 10.2.2.5 Installation or use of parts not manufactured by KARMA.
- 10.2.2.6 Damage resulting from use in unsuitable environments.
- 10.2.2.7 Any addition, modification, or alteration not authorized by KARMA.
- 10.2.2.8 Damage resulting from external factors such as chemicals, oil, debris, etc.
- 10.2.2.9 Natural disaster.

## 10.2.3 KARMA is Not Responsible for the Following Costs

- 10.2.3.1 Replacement or refill of consumable parts, oil, lubricant.
- 10.2.3.2 Inspection, adjustment, cleaning, etc.
- 10.2.3.3 KARMA designated self-inspection costs.

## 10.2.4 Responsibilities

### 10.2.4.1 The Responsibilities of the User

- 10.2.4.1.1 Fully adhere to operation guidelines set forth in this manual.
- 10.2.4.1.2 Perform self-inspection and basic maintenance.
- 10.2.4.1.3 Keep a record of self-inspections and basic maintenance.
- 10.2.4.1.4 Not permit any alteration, addition, or modification or use of parts not manufactured by KARMA.
- 10.2.4.1.5 Thoroughly read and understand this manual.

### 10.2.4.2 The Responsibilities of the Dealer

- 10.2.4.2.1 Follow this manual and educate users about product operation and basic maintenance.
- 10.2.4.2.2 Verify whether or not conditions of warranty have been met.
- 10.2.4.2.3 Provide relevant warranty information and recommendations for improvements.

## 10.2.5 Stipulations

Consumables such as tires, front casters, seat cushions, backrest cushions, etc. are not covered by the warranty.

---

### 10.2.6 Warranty Duration and Parts Covered by the Warranty

Please contact your local dealer.

### 10.2.7 Transfer of Warranty Rights

If you purchase a second-hand KARMA wheelchair while it is still within the warranty period, bring this owner's manual and the wheelchair to the dealer where the wheelchair was purchased for registration.

Full Name:	
Gender:	
Date of Birth:	
Address:	
Model:	
Serial Number:	
Date of Purchase:	

#### **Dealer's Data**

Name of the Store:	
Phone Number and Address:	

If you have any suggestions on how to improve our products, please don't hesitate to contact your local dealer to let us know what you think of your wheelchair. Thank you and enjoy.

# **karma**

National agent:

Sold and serviced by:

**KARMA MEDICAL PRODUCTS CO., LTD.**

[Http://www.KarmaMedical.com](http://www.KarmaMedical.com)

E-mail:[globalsales@karma.com.tw](mailto:globalsales@karma.com.tw)

KARMA reserves the right to modify information herein without further notice.